



American Arms, Inc.

715 E. ARMOUR RD.
N. KANSAS CITY, MISSOURI 64116
PHONE (816) 474-3161 or 474-42-41
TELEX 210333 AMER UR - FAX (816) 4741225



FRANCHI 48/AL

SEMI-AUTOMATIC SHOTGUN

12 Gauge — 20 Gauge
Black Magic Series

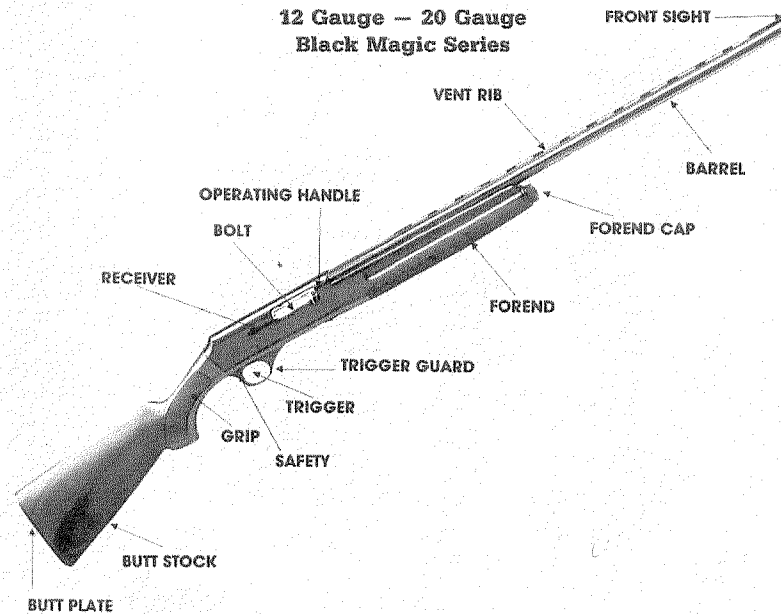

Cod. 4809980405

HONESTLY NOW...

have you read this Owner's Manual?

1 ALWAYS USE THE SAFETY

Everything on the Model 48/AL can be done with the safety "on safe" so keep the safety "on safe" at all times until the moment of firing, to help protect against accidental firing and possible injury or death to yourself or others.

Your Model 48/AL has a cross-bolt safety, just behind the trigger, mounted in the trigger guard. Push it to the LEFT TO FIRE and to the RIGHT FOR "ON SAFE".

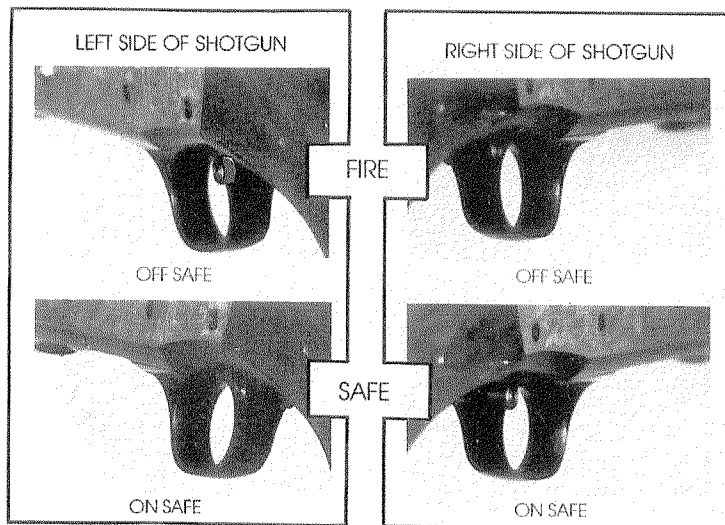

When it is "off safe" you can see a red band on the left side of the safety. When it is "on safe" the red band is inside the trigger guard where you cannot see it.

DON'T RELY ON YOUR SAFETY

Treat every gun like it can fire at any time, even without touching the trigger. The "safety" on a gun is a mechanical device, which, like any device, can stop working at the worst possible time. Besides, by mistake, the safety may be "off" when you think it is "on". The safety adds to proper gun handling, but cannot serve as a substitute for common sense. You should never handle a gun carelessly and assume that it won't fire just because the "safety is on".

2 HOW TO ASSEMBLE THE FRANCHI 48/AL

Your shotgun is packed with the barrel disassembled. Before assembling the gun, check the barrel to be sure the bore is free of anything that could block it during firing. Pieces of styrofoam, the magazine plug, a heavy buildup of oil, or other obstruction could cause a bulged barrel or even a burst barrel when you fire the shotgun.

1. To control the recoil spring, grip the bottom of the forend and pull back toward the receiver. Unscrew the forend cap. Slowly slide the forend off the magazine tube. The recoil spring will stay on the tube.

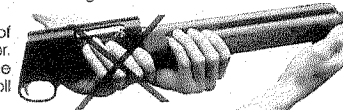

DO NOT SQUEEZE ON THE OPEN PART OF THE FOREND. THIS IS THE MOST COMMON WAY OF CRACKING THE WOOD.

2. Open the bolt by pulling back on the operating handle until the bolt locks open. Be careful not to let the bolt slip. If it stams into the front of the receiver without the barrel in place, it can permanently damage the receiver.



3. Fit the guide collar of the barrel over the end of the magazine tube. Slide it back until the end of the barrel is inside the receiver, and the guide collar stops against the friction ring. Take a firm grip near the muzzle of the barrel and carefully pull back, compressing the recoil spring.

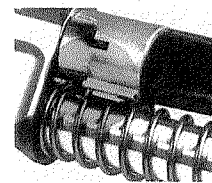
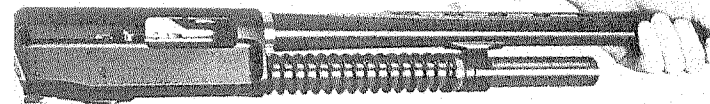

4. When the barrel rails reach the receiver, line them up with their tracks and pull the barrel back into the receiver.

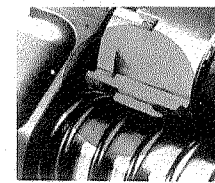

5. Holding the barrel in place, slide the forend onto the magazine tube. Be sure the narrow wood rim at the rear of the forend is fitted inside its recess in the receiver. If it is not, the forend may crack during firing.

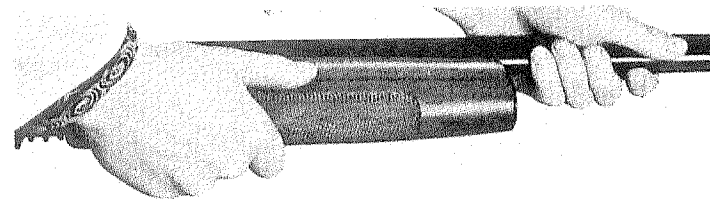

6. Screw the forend cap on tight. This holds the shotgun together, so check it from time to time to be sure it stays tight. HOWEVER, DO NOT USE TOOLS TO TIGHTEN IT.

3 HOW TO SET THE RECOIL GOVERNOR

Your Model 48/AL is recoil-operated. To ensure reliable semiautomatic operation it must be firmly supported by your shoulder when you fire. If you fire it with a relaxed shoulder, or from the hip, it will not have enough resistance to the recoil to ensure reliable ejection and reloading. Also, check the governor ring to be sure it is not set for heavy loads when you are shooting light loads.

The governor ring lets you use both light and heavy loads. It tightens the friction ring for firing heavy loads. Or when reversed it allows the friction ring to slide more freely for light loads. You must adjust it to suit the ammunition you are using.

When it is set correctly the governor ring:

1. Gives reliable semiautomatic operation of the 48/AL.
2. Reduces the amount of recoil you feel.
3. Prevents excessive recoil from abusing your shotgun.

Remove the forend and barrel from the shotgun.

Slide the friction spring and friction ring off the magazine tube.

The governor ring has one side that is flat and one side that is bevelled or chamfered inward.

FOR HEAVY LOADS — BEVELLED SIDE FORWARD

When the bevelled side is forward, toward the friction ring, the friction ring gives more resistance during firing, so you can fire heavy field loads, buckshot and slugs without feeling as much recoil. Using this setting also lets you use heavy loads over the years while protecting your shotgun from wear.

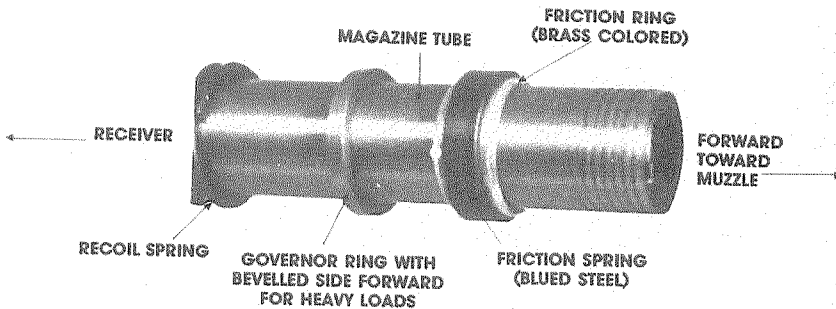

You will feel less recoil when you use the setting for heavy loads. As long as the gun works reliably you should use the heavy load setting. Change to the light load setting only when you are shooting loads that do not give reliable ejection.

DO NOT OIL THE MAGAZINE TUBE. The magazine tube must always be kept clean and dry. WIPE IT DRY AFTER CLEANING.

FOR LIGHT LOADS — FLAT SIDE FORWARD

When the flat side is forward, toward the friction ring, the friction ring slides more easily on the magazine tube. Set the governor ring this way when using light loads or target loads.

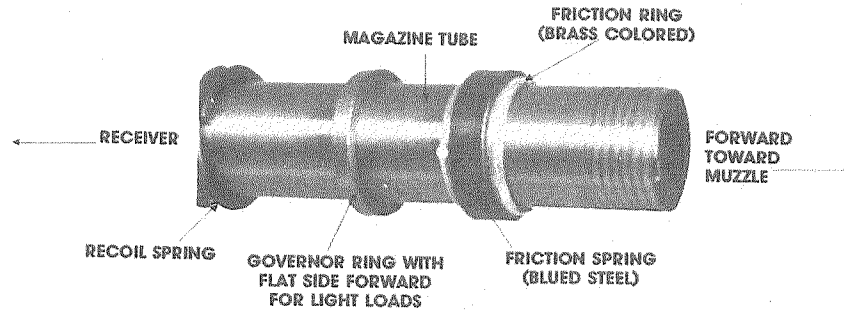

Turn the governor ring to face the way you want, and put it back on the magazine tube next to the recoil spring.

Slide the friction ring onto the magazine tube.

Slip the friction spring onto the magazine tube, and press it onto the friction ring until it is centered on the friction ring.

DO NOT FIRE THE MODEL 48/AL WITHOUT THE FRICTION RING AND SPRING IN PLACE. If you do, you will feel greatly increased recoil, and the severe shock to the action will damage the shotgun. **BEFORE REASSEMBLING THE FOREND, LOOK TO BE SURE YOU PUT THE FRICTION RING AND SPRING BACK ON THE MAGAZINE TUBE.**

Reassemble the barrel and forend.

4 AMMUNITION

Because of the dangers of poor or nonexistent quality control standards among some companies and people who make reloaded ammunition, and the well known fact that dangerous overloads and underloads (squib loads) sometimes occur, we recommend that only good quality factory ammunition be fired in our products. If you prepare your own handloads do not exceed recommended pressures in line with those generated by standard factory loads as manufactured by Remington, Winchester, Federal or other reputable companies.

5 HOW TO LOAD

Before loading with live ammunition, read the rest of this manual so you understand how to handle the firearm safely. Read the "AMMUNITION" section again before loading any ammunition into this firearm.

LEARN THIS FIRST! The model 48/AL only feeds shells from the magazine when it is fired. You cannot load the chamber by loading the magazine and then manually operating the bolt.

Put the safety "on safe".

Hold the gun upside down, with your finger on the carrier latch button. **PRESSING THE CARRIER LATCH BUTTON CLOSSES THE BOLT. BE CAREFUL TO AVOID BEING STRUCK BY THE OPERATING HANDLE OR PINCHED BY THE CLOSING BOLT.** Press the carrier latch button and hold it in.

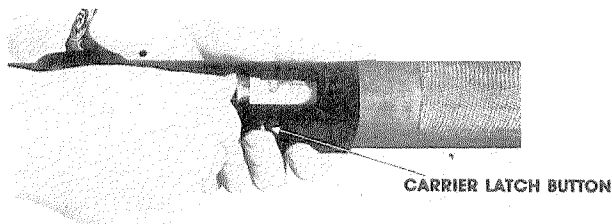

With a 2-3/4" shell (or 3" if you own the Magnum model), push down on the carrier and push the shell forward into the magazine. Be sure you push it all the way in. Repeat this until the magazine is full (2 shells with the magazine plug installed, or 4 shells without the plug).

Turn the shotgun right side up.

Pull back on the operating handle until you feel and hear the bolt lock open.

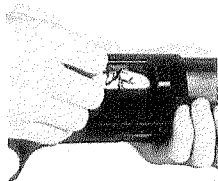

Put a shell into the receiver. You do not have to get into the chamber of the barrel. Just drop it into the receiver.

Press the carrier latch button on the left side of the receiver to close the bolt.

WARNING: THE GUN IS NOW LOADED AND READY TO FIRE. KEEP IT POINTED IN A SAFE DIRECTION. REMEMBER: DO NOT RELY ON THE SAFETY AS A SUBSTITUTE FOR SAFE GUN HANDLING.

The Model 48/AL uses only 2-3/4" shells (birdshot, buckshot, slug or magnum). Only the Model 48/AL Magnum model is chambered for 3" shells, allowing the use of both 2-3/4" and 3" shells.

6 HOW TO FIRE

Keep the safety "on safe".

The recoil-operated action will not work if you fire from the hip or from a relaxed-shoulder stance. You must give the shotgun firm support during firing. If the gun moves too freely during recoil, it absorbs too much of the recoil needed to work the semiautomatic mechanism.

There are only 2 main reasons for failure to eject or failure to feed:

1. Governor ring is set for heavy loads when firing light loads.
To CORRECT THIS see Section 3.
2. Shooter is not giving firm resistance to recoil.
To CORRECT THIS adopt a good stance and shoot from the shoulder.

Keep your finger off the trigger and out of the trigger guard.

Select a safe firing area with a backstop or clear zone for falling shot.
Push the safety to "off safe".

THINK! What will you **HIT** if you **MISS** the target?

Aim and squeeze the trigger to fire.

7 HOW TO UNLOAD

Keep the safety "on safe".

Pull the operating handle back until the bolt locks open. This removes the shell from the chamber.

THERE ARE 2 WAYS TO UNLOAD THE MAGAZINE:

1. Hold the bolt open with one hand.
Press the carrier latch button. (This releases the bolt, so keep a good grip on the operating handle.)
Flip the carrier up and reach in with your finger.
Press the shell latch, which is left of the shell head (you can see it holding the rim of the shell), and one by one the shells will come out of the magazine.

2. Close the bolt after checking to be sure the chamber is empty.

Follow the same steps as in No. 1.

You will find that you have to wiggle the shell up and down a little to get it past the front lip of the carrier.

Doing it this way means you do not have to hold the bolt open.

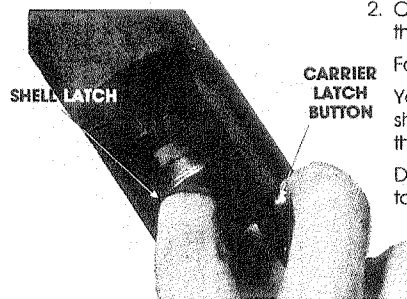

8 HOW TO PLUG THE MAGAZINE

DON'T MAKE AN EASY JOB HARD! THERE ARE MANY **WRONG** WAYS TO PUT THE PLUG IN. **NONE OF THEM WORK.** HERE'S HOW TO DO IT **RIGHT.**

WEAR EYE PROTECTION. The magazine spring is under tension. It can fly out and pierce the eye, causing **BLINDNESS.**

Unscrew the forend cap, and remove the forend and barrel. Notice the thin steel walls of the magazine tube. BE CAREFUL NOT TO BEND THEM OR DAMAGE THE THREADS.

You can see the magazine spring retaining ring and magazine spring inside the tube. The retaining ring keeps the spring in the tube. When you remove it, the spring (which is LONG and STRONG) will be free to expand out of the tube. BE CAREFUL. With a hooked tool or screwdriver, gently pull or pry the retaining ring out of the magazine tube. You will need the retaining ring again later so USE YOUR FREE HAND TO CONTROL IT AND THE MAGAZINE SPRING AS YOU REMOVE THE RETAINING RING, so you do not lose it.

Keep the magazine spring in the tube.



Put the long narrow part of the magazine plug in the end of the magazine spring, so the wide end of the plug rests against the end of the spring.



Push the plug and spring into the tube. If the wide part of the plug does not fit easily into the tube you may have to trim the sharp shoulder edge a little. It may also need to be tapped in carefully with a plastic or rubber mallet.

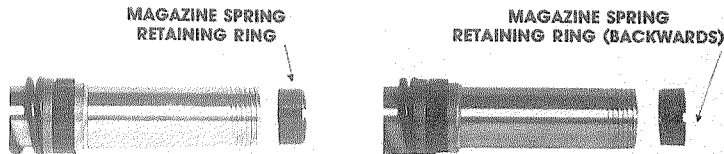

Replace the retaining ring. If you cannot compress it enough to install it right side up, you may turn it over. The rounded shoulders will help you press it into the tube.

Be sure you replace the retaining ring. If you do not, the magazine spring may fly out whenever you remove the forend cap, possibly injuring you or others.

If you lose the retaining ring you can get a new one by sending \$4.00 (specify 12 ga. or 20 ga.) to AMERICAN ARMS, INC., 715 E. ARMOUR RD., N. KANSAS CITY, MISSOURI 64116.

9 FIELD STRIPPING AND MAINTENANCE

DISASSEMBLY

Open the bolt by pulling back on the operating handle until you feel and hear the bolt lock in its rearward position.

Look in the chamber and magazine to be sure the shotgun is unloaded.

Grip the barrel and pull back toward the receiver.

Unscrew the forend cap.

Slide the forend forward off the magazine tube. BE CAREFUL NOT TO SQUEEZE THE OPEN PART OF THE WOOD, OR YOU WILL CRACK THE FOREND.

Ease the tension on the barrel and remove it.

TAKE A FIRM GRIP ON THE OPERATING HANDLE. USE CAUTION SO IT DOES NOT SLIP FROM YOUR GRASP. PRESS THE CARRIER LATCH BUTTON ON THE LEFT SIDE OF THE RECEIVER AND SLOWLY CLOSE THE BOLT. DO NOT LET THE BOLT SLAM FORWARD WITHOUT THE BARREL SECURELY IN PLACE. PERMANENT DAMAGE TO THE RECEIVER COULD RESULT.



Remove the friction rings and recoil spring from the magazine tube.

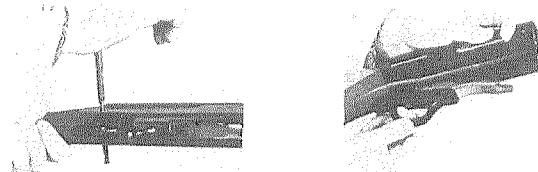

Remove the trigger assembly by using a proper size punch to drive out the two retaining pins. Disassembly of the trigger mechanism is not recommended and not necessary for cleaning.

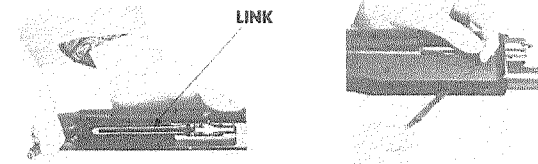

Looking into the receiver you see the bottom of the bolt assembly and the long double-rail link. The rear of the link fits into the follower for the action spring. The action spring can be seen going back into the stock.

Press the action spring follower back and release the link. Slide the bolt back and let the operating handle slip out of its slot. WATCH HOW THEY COME APART! You will be trying to figure out how to get them back together in a few minutes.

Use the link to slide the bolt forward again. Then press down and forward on the link to push the bolt assembly out of the receiver.

Remove the operating handle.

NO MORE DISASSEMBLY IS NEEDED OR RECOMMENDED. DO NOT TAKE APART THE TRIGGER ASSEMBLY OR BOLT ASSEMBLY. DO NOT TRY TO REMOVE THE MAGAZINE TUBE OR THE ACTION SPRING ASSEMBLY.

FIELD STRIPPING AND MAINTENANCE

(continued)

KEEP THE BUTT STOCK TIGHT

A long bolt through the butt stock fastens it to the receiver. This bolt sometimes works loose a little bit, due to the recoil action of the shotgun.

A LOOSE STOCK IS THE MOST COMMON CAUSE OF A CRACKED OR CHIPPED STOCK WHERE IT JOINS THE RECEIVER. TO KEEP YOUR STOCK FROM CRACKING OR CHIPPING, KEEP IT TIGHT.

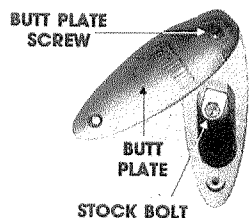

Check the tightness every 100-200 shots. During hunting seasons or other times of heavy use, check the stock bolt itself to be sure it stays tight.

Unscrew one butt plate screw all the way, and loosen the other screw a few turns.

Swing the butt plate aside and tighten the stock bolt with a large screwdriver or long neck socket wrench.

CLEANING

Use nitro solvent and a light gun oil to clean and lubricate the bore. Clean the bolt assembly and upper receiver with solvent, then apply a light coat of oil.

A small brush will work better than a cleaning patch in some areas, such as the receiver and the trigger group.

Too much oil can eventually become gummy and cause sticking of parts and malfunctions. You must oil the steel surfaces to guard against rust, but do so sparingly.

REASSEMBLY

Put the bolt part way back into the receiver. Put the operating handle in through the ejection port. Fit them together.

Push the link down, press back on the operating spring, and fit the end of the link into the recess of the operating spring follower.

Slide the trigger assembly into the receiver and replace the pins.

Sections 2 and 3 of this manual show how to finish reassembly.

WARNINGS

READ THIS AND BE A SAFE SHOOTER

Never point a gun at any person or thing you don't intend to shoot.

Treat every gun as if it is loaded... all the time.

Get instructions from a competent firearms instructor before using any gun.

Never rely on a gun's "safety" to protect you from unsafe gun handling. A safety is only a mechanical device, not a substitute for common sense.

Keep your finger off the trigger until you are actually aiming at the target ready to shoot.

Be certain the gun is unloaded before cleaning.

Always empty guns before entering a house, car, truck, boat, RV, camp or any building.

Never leave a loaded gun unattended.

Store guns and ammunition separately beyond the reach of children.

Don't "test the safety" by pulling the trigger while the safety is on.

Don't try to change your gun's trigger pull, because alterations of trigger pull usually affect sear engagement and may cause accidental firing.

If you do drop your gun, unload it and check it for proper function before using it again.

Always wear fluorescent orange vest, hat or jacket when in the woods or fields.

If a gun fails to fire when trigger is pulled, keep it pointed at target for at least 30 seconds. Sometimes slow primer ignition will cause a "hang fire" and the cartridge will go off after a short pause.

Never leave a gun where it could fall and fire.

WARNING

ANY BORE OBSTRUCTION, EVEN IF IT IS ONLY PARTLY BLOCKED, MAY CAUSE THE FIREARM TO BLOW UP IF IT IS FIRED, OR MAY CAUSE DAMAGE TO THE GUN SUCH AS A BULGED BARREL. TO AVOID INJURY OR DEATH TO THE SHOOTER OR BYSTANDERS, CHECK THE BARREL BEFORE SHOOTING OR IF A SHOT DOES NOT SOUND NORMAL.

Keep the barrel bore and chambers free of any obstruction or blockage. Heavy oil or grease, dirt, or even snow can be dangerous. If you hear a weak or peculiar shot when firing, immediately stop firing. Unload the firearm and check the barrel.

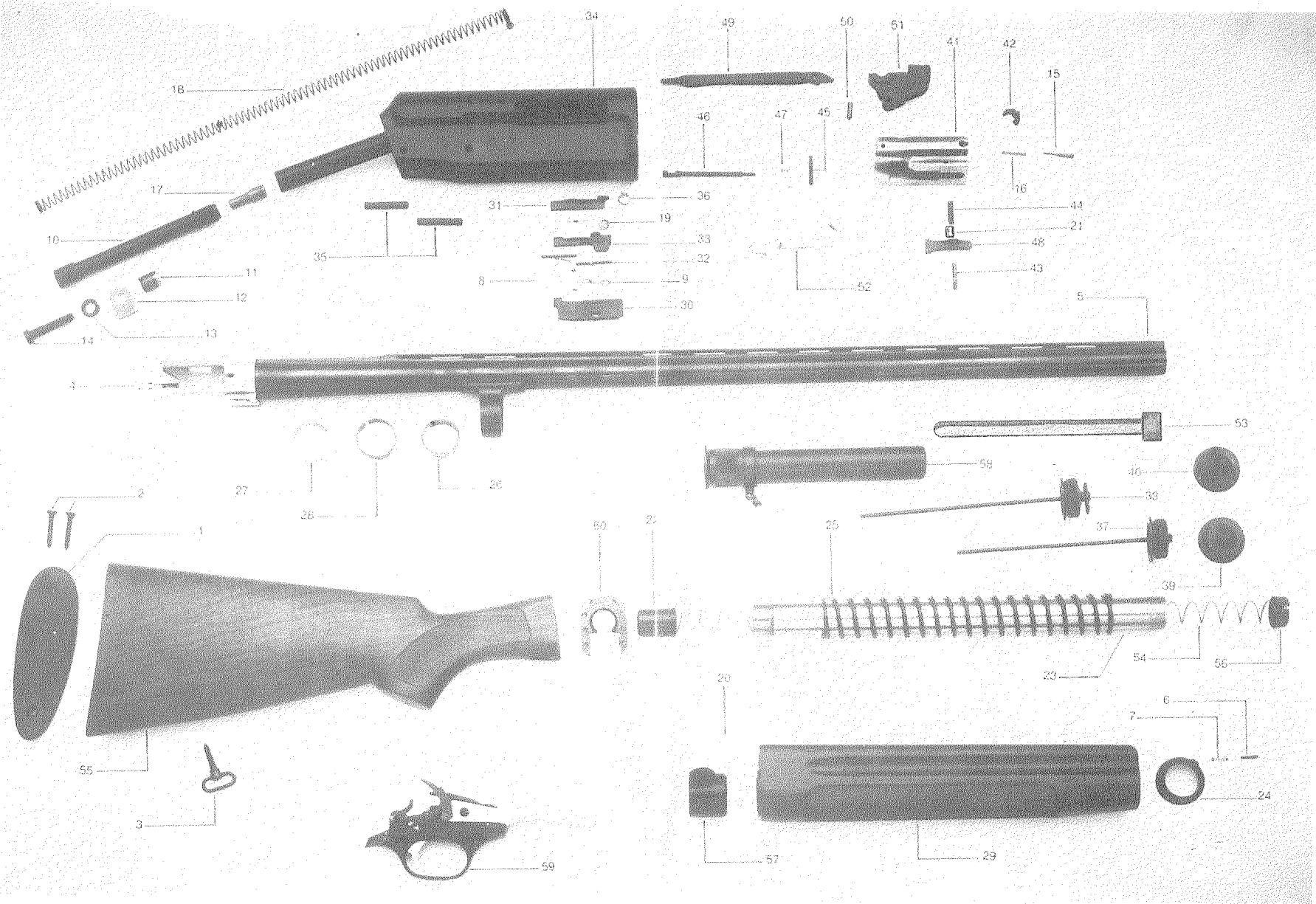

N°	COD.	DESCRIPTION	PRICE
1	2141450020	Standard recoil pad	B3
2	3141890020	Recoil pad screw	A1
3	3141090010	Stock swivel	A5
4	2141560010	Ejector 12 ga.	B5
4	2142560010	Ejector Magnum 12 ga.	C1
4	2144660010	Ejector 20 - 28 ga.	B5
4	2145600010	Ejector Magnum 20 ga.	C1
5	3141680010	Carrier latch spring	A1
6	3141760010	Magazine cap retaining pin	A1
7	3144690020	Magazine cap retaining pin spring	A1
8	3141690060	Carrier latch spring	A1
9	3141690050	Shell and carrier latch pin spring	A1
10	3141880020	Action spring tube	E6
11	3141850010	Action spring plug	A5
12	3141780010	Stock fastening plate	A1
13	3141780020	Stock fastening elastic washer	A1
14	3141890010	Stock fastening screw	A1
15	3141760030	Extractor plunger	A1
15	3148760010	Extractor plunger 28 ga.	A1
16	3141690080	Extractor spring	A1
17	3141760020	Action spring follower	A5
18	3141690040	Action spring	A5
19	3141690070	Shell and auxiliary latch spring	A5
20	3141690010	Nylon ring spring	A1
21	3141430030	Locking block lever follower	A1
22	3141500010	Magazine follower 12	B5
22	3144500010	Magazine follower 20	B5
22	3148500010	Magazine follower 28	B5
23	3141880010	Magazine 12	G1
23	3144880010	Magazine 20 - 28	F1
24	3141430010	Front nylon ring 12	A1
24	3144430010	Front nylon ring 20 - 28	A1
25	3141690030	Recoil spring 12	D1
25	3144690030	Recoil spring 20	D1
25	3142690030	Recoil spring 12 Magnum	D1
25	3145690030	Recoil spring 20 Magnum	D1
25	3148690010	Recoil spring 28	D1
26	3141360040	Friction ring 12	B5
26	3144360040	Friction ring 20 - 28	B5
26	3142360020	Friction ring Magnum	A5
27	3141360020	Governor ring 12	A5
27	3144360020	Governor ring 20 - 28	A5
27	3142360010	Governor ring Magnum	A5
28	3141690180	Friction spring 12	A1
28	3144690180	Friction spring 20 - 28	A1
29	3141380010	Standard forend 12	M1
29	3144380010	Standard forend 20	M1
29	3148380010	Standard forend 28	M1
29	3142380010	Forend Magnum 12	M1
29	3145380010	Forend Magnum 20	M1
30	3141640030	Carrier Latch 12	D1
30	3144640030	Carrier Latch 20	D1
30	3148640030	Carrier Latch 28	D1
31	3141640020	Auxiliary shell latch 12	B5
31	3144640020	Auxiliary shell latch 20 - 28	B5
32	3141740020	Shell and aux. latch pin 12	A1
32	3144740020	Shell and aux. latch pin 20 - 28	A1

N°	COD.	DESCRIPTION	PRICE
33	3141640010	Shell Latch 12	B5
33	3144640010	Shell Latch 20	B5
33	3148640010	Shell Latch 28	B5
35	3141740010	Trigger guard pin 12	A5
35	3144740010	Trigger guard pin 20	A5
36	3141420010	Carrier latch button 12	A5
36	3144420010	Carrier latch button 20	A5
36	3141420360	Gilded carrier latch button 12	B5
36	3144420360	Gilded carrier latch button 20	B5
37	3141180210	2 shot plug forend cap without swivel 12	.
37	3144180210	2 shot plug forend cap without swivel 20	.
37	3141180270	3 shot plug forend cap without swivel 12	.
37	3144180270	3 shot plug forend cap without swivel 20	.
38	3141180200	2 shot plug forend cap with swivel 12	.
38	3144180200	2 shot plug forend cap with swivel 20	.
38	3141180260	3 shot plug forend cap with swivel 12	.
38	3144180260	3 shot plug forend cap with swivel 20	.
39	3141490020	Forend cap without swivel 12	F1
39	3144490020	Forend cap without swivel 20	F1
40	3141180010	Forend cap with swivel 12	F6
40	3144180010	Forend cap with swivel 20	F6
41	3141720010	Breech block 12	G1
41	3144720010	Breech block 20	G1
41	3148720010	Breech block 28	G1
42	3141570010	Extractor 12	B5
42	3144570010	Extractor 20	B5
42	3148570010	Extractor 28	B5
43	3141740030	Locking block lever pin 12	A1
43	3144740030	Locking block lever pin 20 - 28	A1
44	3141690090	Locking block lever spring 12	A1
44	3144690090	Locking block lever spring 20	A1
45	3141740040	Firing pin stop 12	A1
45	3144740040	Firing pin stop 20	A1
46	3141730010	Firing pin 12	B5
46	3144730010	Firing pin 20 - 28	B5
47	3141690020	Firing pin spring 12	A1
47	3144690020	Firing pin spring 20	A1
48	3141640040	Locking block lever 12	B5
48	3144640040	Locking block lever 20	B5
49	3141370010	Link 12	E6
49	3144370010	Link 20 - 28	E6
49	3142370010	Link 12 Magnum	G1
50	3141740050	Link pin 12	A1
50	3144740050	Link pin 20	A1
51	3141860010	Locking block 12	G7
51	3144860010	Locking block 20 - 28	G7
52	3141660010	Operating handle 12	G9
52	3144660010	Operating handle 20	G9
52	3142660010	Operating handle 12 Magnum	H4
53	3141370100	Multiple shot plastic plug	B1
53	3144370020	5/3 shot plastic plug 20	B1
54	3141690110	Magazine spring 12	A5

N°	COD.	DESCRIPTION	PRICE
54	3144690110	Magazine spring 20	A5
54	3142690110	Magazine spring 12 Magnum	A5
55	3141081190	Stock St. drop A.H. 2" - 12	P1
55	3141081590	Stock St. drop A.H. 2 1/4" - 12	P1
55	3141081390	Stock St. drop A.H. 2 1/2" - 12	P1
55	3144081190	Stock St. drop A.H. 2" - 20	P1
55	3144081590	Stock St. drop A.H. 2 1/4" - 20	P1
55	3144081390	Stock St. drop A.H. 2 1/2" - 20	P1
55	3142081120	Stock Magnum drop A.H. 2" - 12	G1
55	3142081520	Stock Magnum drop A.H. 2 1/4" - 12	G1
55	3142081320	Stock Magnum drop A.H. 2 1/2" - 12	G1
55	3145081120	Stock Magnum drop A.H. 2" - 20	G1
55	3145081520	Stock Magnum drop A.H. 2 1/4" - 20	G1
55	3145081320	Stock Magnum drop A.H. 2 1/2" - 20	G1
55	3141081192	Stock L.H.S. drop A.H. 2" - 12 Standard	R1
55	3141081592	Stock L.H.S. drop A.H. 2 1/4" - 12 Standard	R1
55	3141081392	Stock L.H.S. drop A.H. 2 1/2" - 12 Standard	R1

N°	COD.	DESCRIPTION	PRICE
55	3144081192	Stock L.H.S. drop A.H. 2" - 20 Standard	R1
55	3144081592	Stock L.H.S. drop A.H. 2 1/4" - 20 Standard	R1
55	3144081392	Stock L.H.S. drop A.H. 2 1/2" - 20 Standard	R1
55	3141081494	Straight stock drop A.H. 2 1/2" - 12	R1
56	3141360030	Magazine spring retaining ring 12	A5
56	3144360030	Magazine spring retaining ring 20	A5
57	3141360010	Nylon ring 12	A5
57	3144360010	Nylon ring 20	A5
58	3A41180100	Magazine extension 12	.
59	3141140010	Trigger guard assembly 12 St.	P1
59	3144140010	Trigger guard assembly 20 St.	P1
59	3141140360	Trigger guard assembly 12 Gilded trigger	G1
60	3141790010	Stock buffer 12	B5
60	3144790010	Stock buffer 20	B5

* See shotgun's price list

48/AL

WARNING

THIS GUN WAS MANUFACTURED TO PERFORM PROPERLY WITH THE ORIGINAL PARTS AS DESIGNED IT IS YOUR DUTY TO MAKE SURE ANY PARTS YOU BUY ARE INSTALLED CORRECTLY AND THAT NEITHER REPLACEMENTS NOR ORIGINALS ARE ALTERED OR CHANGED. YOUR GUN IS A COMPLEX TOOL WITH MANY PARTS THAT MUST RELATE CORRECTLY TO OTHER PARTS. PUTTING A GUN TOGETHER WRONG OR WITH MODIFIED PARTS CAN RESULT IN A DAMAGED GUN, DANGER, AND INJURY OR DEATH TO YOU AND OTHERS THROUGH MALFUNCTION. ALWAYS LET A QUALIFIED GUNSMITH WORK ON YOUR GUN OR AT LEAST CHECK ANY WORK NOT PERFORMED BY A GUNSMITH. WE AT A.A. THINK THIS IS A SMALL PRICE TO PAY FOR FIREARMS SAFETY.